

**SOLAR PANEL FRAME**

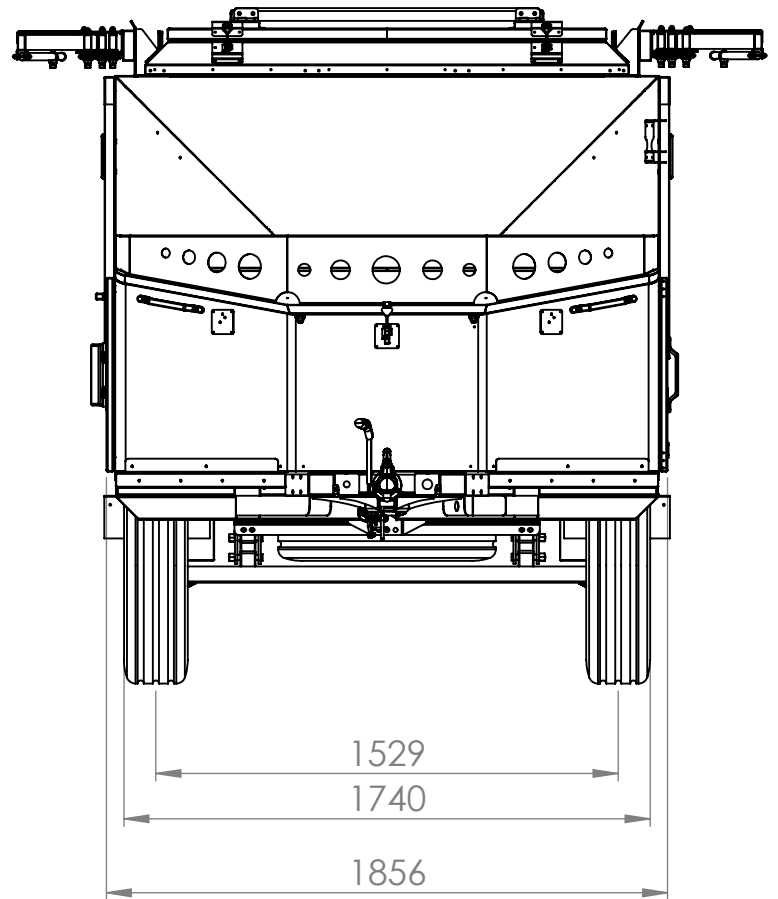

**CONSTRUCTION  
3CR12 STAINLESS AND ALUMINIUM**

**KITCHEN**

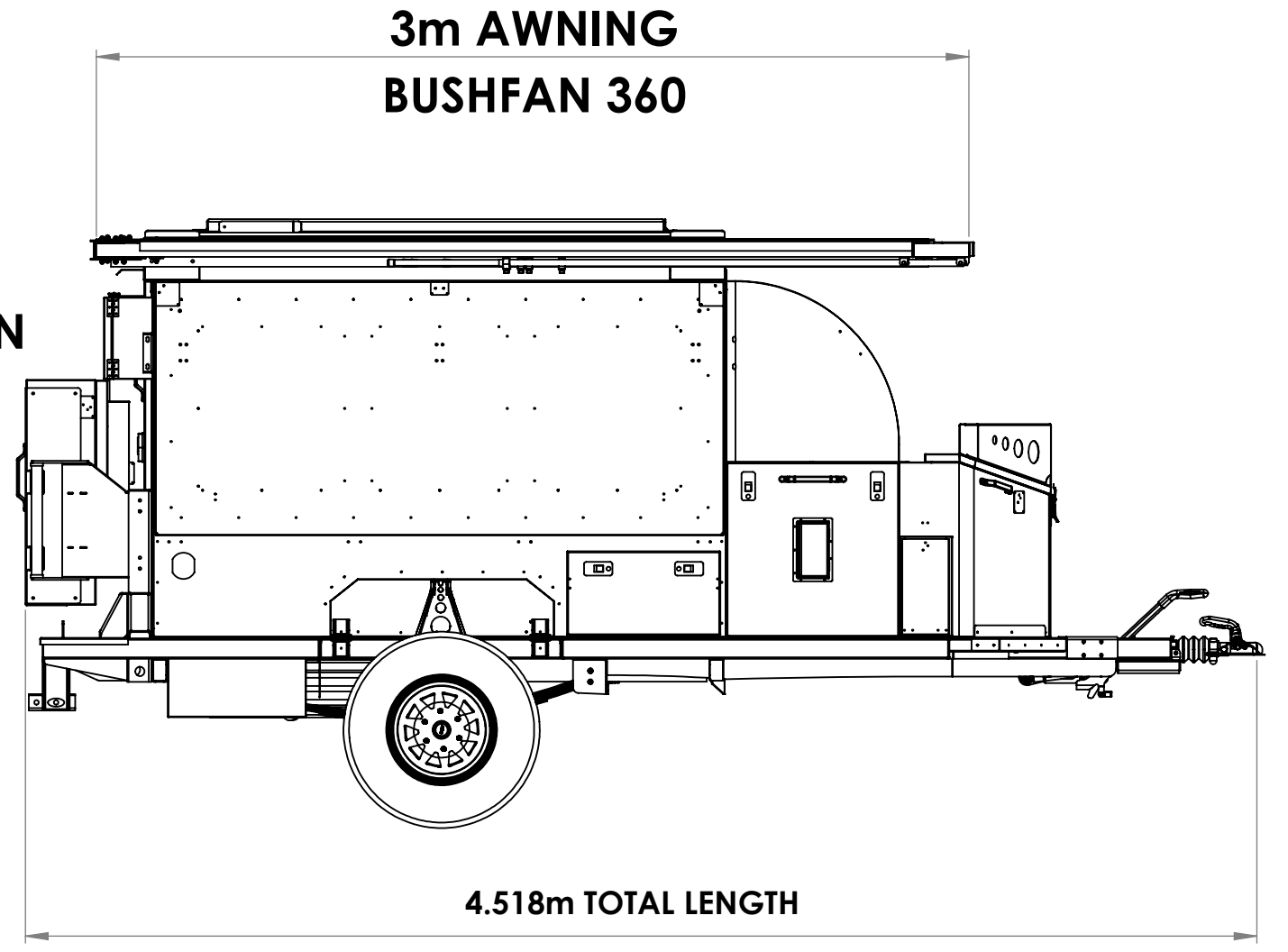

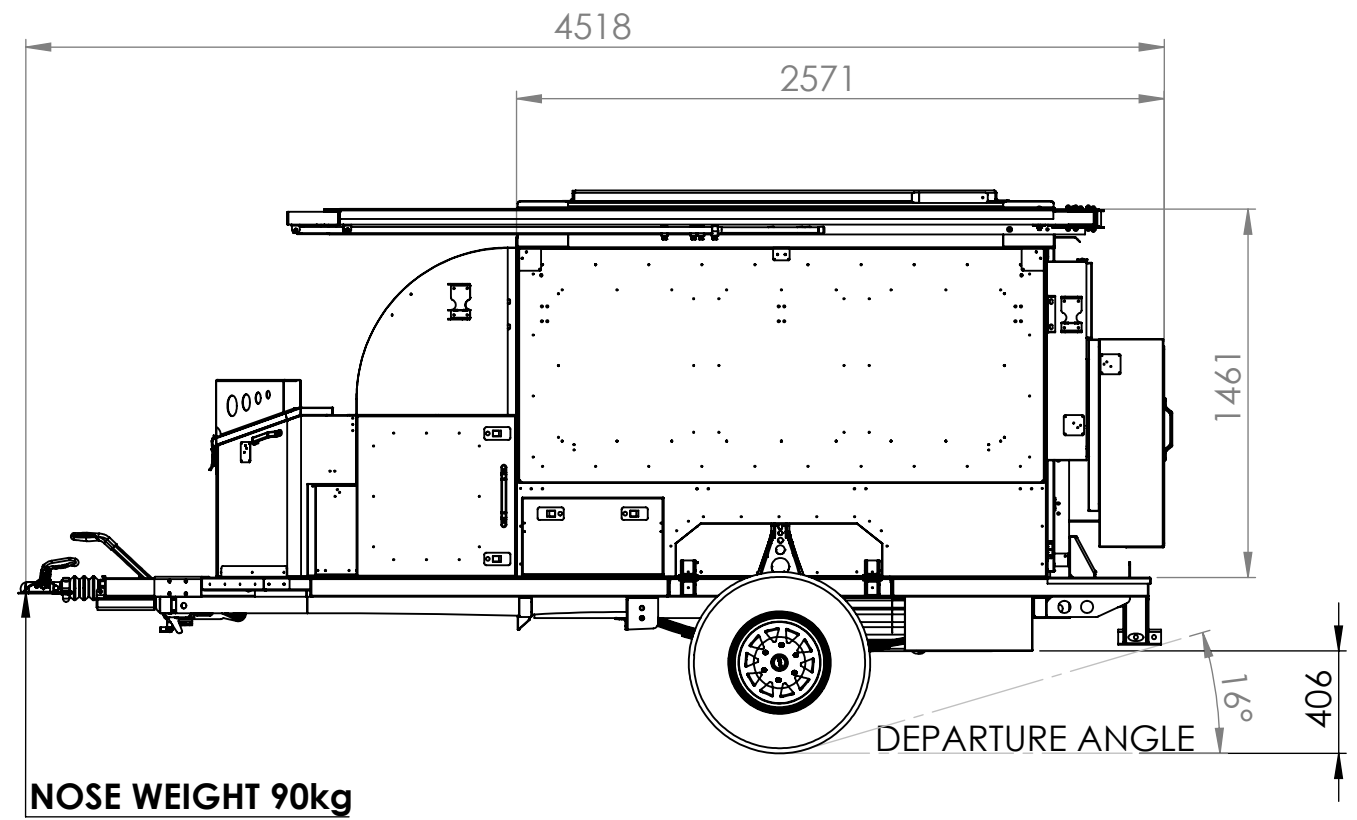
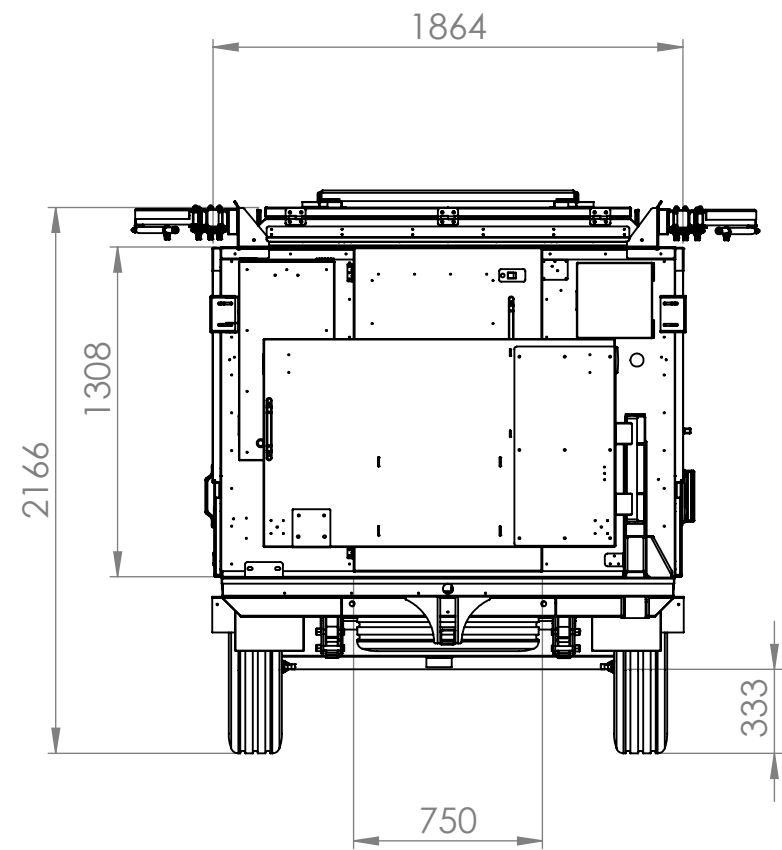

**GVM: 1700kg**  
**TARE: 1500kg**  
**AXLE: 2500kg Braked**  
**COUPLER: 2700kg Braked**